

Telecom/IT Battery Systems

AGV Battery Systems

Motive Power Systems

Railway Battery Systems

Power Supply

Standby

AGV power supply for automatic guided vehicle systems



Power from Innovation

Power supply for automatic guided vehicles

Robot vehicles link up points of manufacture and production lines. They serve as mobile assembly points and as a means of conveyance. But nowadays they are also commonly employed in stores, depots and for internal transport, including shelf conveyor installations. High standards are set for the availability, ease of maintenance and security of the power supply of automatic guided vehicle systems. HOPPECKE batteries demonstrate their reliability in day-to-day use.

An adequate and constantly available power supply is the basic precondition for the functioning of AGV systems as a means of conveyance. While control is exercised externally by central computer, the AGV robot carries its energy source around with it: the HOPPECKE battery is installed on the vehicle.

Sensors on the vehicle pick up the magnetic field generated by the flowing current and direct the vehicle along the centre of the induction loop. It follows the prescribed course to its destination.

The exchange of information between vehicle and control centre takes place via the induction loop. The vehicle gives its status report and receives new commands.

The onboard control system of the AGV carries out the internal regulation and control functions: setting the route, forward or reverse running, steering, execution of additional movements, together with loading and unloading. In addition, discharge capacity is checked and, if necessary, charging is initiated.

An overriding control system allocates the work to be performed among the AGVs available, controls the flow of materials and ensures correct performance of the work.

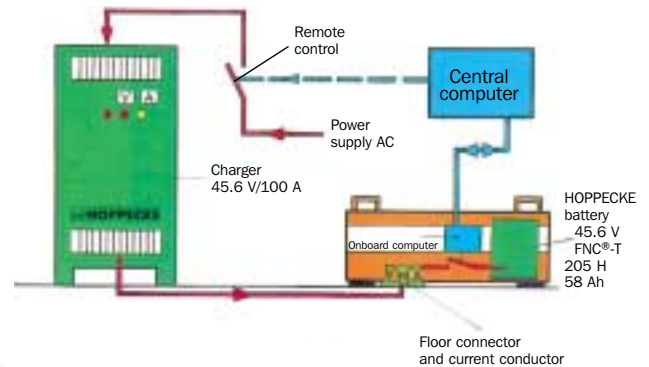

Nothing runs without the battery

The choice of power supply for an AGV system depends on many parameters related to the nature and place of use. 98% availability for production purposes is assumed.

We can distinguish between 4 criteria for selecting the optimal battery:

- mechanical structure of the vehicle (work to be performed)
- type of use of the vehicles
- usable capacity (running, standing and loading times)
- maintenance and working life.

Everything from one source

The HOPPECKE range for AGV installations will comprise not only the hardware such as battery, charger, computer and connecting elements e. g. automatic contacts and busbar systems, but HOPPECKE will also supply the user with all necessary software, so that he can choose a complete turnkey package.

The HOPPECKE battery and charger systems are tailor made for AGV systems. The system which is actually used depends on the application and workload of the AGV system.

The hardware which supplies an AGV system with power comprises the battery, charging system and contact devices. But software is also an important factor in linking all components together, thereby providing the maximum degree of information for the operator. Only by this means can maximum flexibility and uninterrupted operation be ensured.

HOPPECKE provides everything required from a single source: complete packages and answers to your needs.

AGV SUPPORT - PROBLEM-SOLVING - IMPLEMENTATION

HOPPECKE Engineering for AGV systems

HOPPECKE design AGV systems and monitor their installation. Countless installations throughout the world testify to the wealth of experience of HOPPECKE engineers. This represents knowledge which is available for you. For this reason, customers should call in HOPPECKE specialists right at the planning stage, so that the correct route can be taken from the start and time-consuming detours avoided.

Transport systems are simulated right at the design stage using the most up-to-date computer facilities. CAD systems support the work of HOPPECKE engineers.



An AGV system is as flexible as its power source permits

AGV systems are used in the most varied applications, offering a high degree of flexibility to the operator. The power source represents an important critical factor at the planning stage.

Intensive analyses are necessary to determine the most economic type of power supply.

A large number of installations already in operation speak for HOPPECKE's experience.

Battery charging is a matter of seconds - for example, while running or standing, during waiting periods, during assembly work or at handover points.

Different types of battery, rectifier, contacts and automatic charging stations may be used, depending on the application.

HOPPECKE installation staff will also take care of minor chores like for example the installation of electrical facilities and of water treatment facilities to prepare the deionized water needed for battery maintenance. HOPPECKE will not leave you with loose ends untied. Engineering, practical assistance with installation, and software from HOPPECKE - all this from a single source.

HOPPECKE will supply all components required for the energy supply of an AGV system.



FNC®-T / minitrak - compact dimensions, reliable performance

HOPPECKE FNC®-T - Batteries with fibre-structured electrodes

NiCd-batteries of the FNC®-T series were developed by HOPPECKE for use in electric vehicles and industrial trucks. They have been in use since 1983 in all known traction applications. The fibre-structured electrodes meet the most demanding requirements for power supplies.

- exceptionally high cyclic reliability
- extremely low internal resistance
- extremely short charging times
- minimized maintenance requirement
- mechanical and electrochemical stability

For automated guided vehicle systems (AGV) batteries are needed which are robust, have a high cycle ability, a high performance and are easy to maintain. Of course, they are also in use, where a long service life and economy are required. With their unique technology, HOPPECKE FNC®-T batteries meet these requirements.

In comparison with pocket-plate electrodes, fibre structure electrodes offer many advantages.

trak® powerpack with specially reinforced grid plates and special insulation for medium cyclic loads.

ENERGY batteries are suitable as traction batteries in small industrial trucks, hand platform stackers, sweepers and invalid wheelchairs.

HOPPECKE minitrak H with tubular plates for high cyclic loads

H series minitrak batteries are to be preferred for electric vehicles applications a automated guides vehicles (AGV), industrial robots electric road vehicles, power supplies for mobile measuring units, electrically driven boats, go-carts, golf carts, lift-trucks, vertical platforms and sweepers.



trak® powerpack



FNC®-T

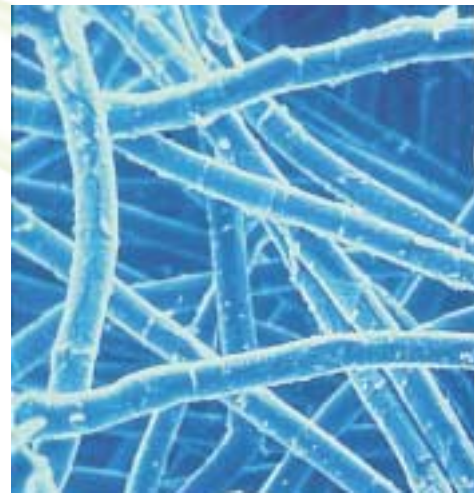

fibre-structured electrode

Traction batteries and chargers for small electric vehicles

trak® powerpack and **minitrak H** both versions share the following features:

- compact dimensions
- easy maintenance
- translucent polypropylene cases allows easy checking of electrolyte level



minitrak H

Charging systems

HOPPECKE chargers with universal charge controllers and Ah-Counters for the optimal charging of traction batteries and power monitoring in forklift trucks.

These chargers can be installed in a system-dependent manner on-board or in stationary locations. For automatic guided vehicle systems, battery chargers are PLC/microprocessor-controlled and equipped with hardware and software interfaces according to customer specifications.

Charging procedures / charging characteristics

In principle, all W and IU (1) charging procedures can be used. Charging is initially carried out at a constant charging current up to 1.55 V/cell, 1.65 V/cell. Charging is then continued at this constant voltage with a decreasing current. A programmed "charge end current" allows for the charge factor and for switching down to the float charge voltage of 1.45 V/cell. (These chargers (a) are controlled via PLC). The chargers (b) of the type range FRFT are equipped with a microprocessor, which controls the charging process. With the IUa (2) characteristic, initially a constant charging current is applied until the desired cell voltages of 1.55 to 1.65 V/cell are reached. Charging then continues at constant voltage until the charging current falls to the programmable i_{le} value. The charger has finished its charge cycle, the vehicle is ready for the next order. If there is no order (for example at weekends), and the AGV is always on charge position, a programmable timer (t_1) starts, and the charger supplies a booth charge cycle within 1-24 hours, depending on the sleep current of the vehicle. The state of the charging process can permanently be checked via LEDs in the front panel of the chargers or via potential free contacts which can be used to communicate the information to the host computer. Charger settings like current, voltage, timers etc. can be changed using a PC connected to the charger, if necessary. The end of charge parameters of the last 32 charging processes and failure reports are stored in the charger. They are accessible via a PC and can be used for system analysis. All chargers are able to supply a maintenance charge cycle with I_a characteristic, constant current (I_5) and open voltage.



(a)

(b)

HOPPECKE has the best energy source for every application

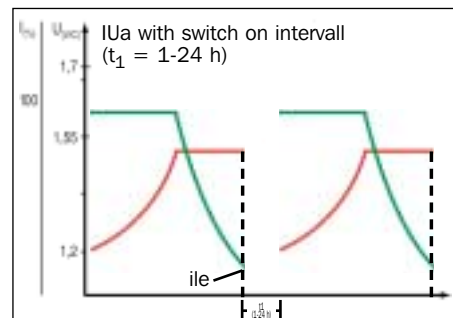
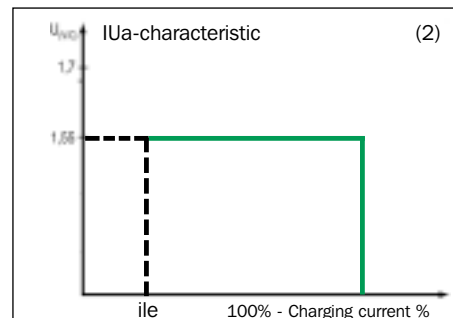
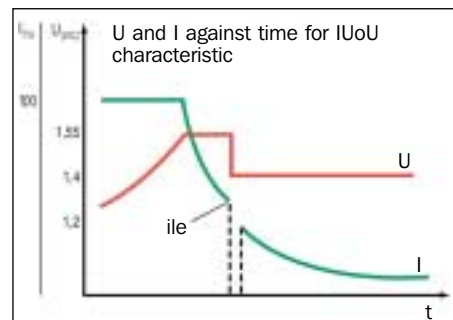
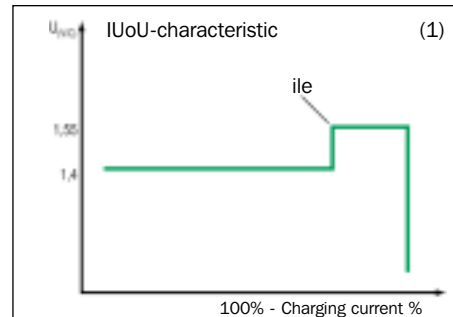

AGV TYPE LIST NiCd - FNC®-T

Cell designation	C ₅ in Ah	Dimensions of cells in mm			weight incl. electrolyte in kg	electrolyte nominal in kg	current I ₅ in A
		length	width	height			
NiCd-Cells with fibrestructured electrodes							
T 103 H	26	47	122	250	2.1	0.65	5.2
T 104 H	35	47	122	250	2.3	0.55	7.0
T 105 H	44	72	122	250	3.2	1.05	8.8
T 106 H	52	72	122	250	3.4	0.95	10.4
T 107 H	60	72	122	250	3.6	0.84	12.0
T 108 H	70	92	122	250	4.4	1.22	14.0
T 109 H	78	92	122	250	4.6	1.12	15.6
T 110 H	86	115	122	250	5.4	1.57	17.2
T 111 H	95	115	122	250	5.6	1.47	19.0
T 203 H	35	47	122	309	2.9	0.59	7.0
T 204 H	46	47	122	309	2.8	0.50	9.2
T 205 H	58	72	122	309	4	1.08	11.6
T 206 H	69	72	122	309	4.2	1.00	13.8
T 207 H	80	72	122	309	4.7	0.90	16.0
T 208 H	93	92	122	309	5.5	1.30	18.6
T 209 H	104	92	122	309	5.9	1.15	20.8
T 210 H	115	115	122	309	7	1.55	23.0
T 211 H	125	115	122	309	7.4	1.42	25.0
T 307 H	140	92	194	309	8.7	2.00	28.0
T 308 H	160	92	194	309	8.8	1.90	32.0
T 309 H	180	92	194	309	9.2	1.80	36.0
T 310 H	200	115	194	309	10.9	2.00	40.0
T 311 H	220	115	194	309	11.3	1.90	44.0
T 312 H	240	115	194	309	11.7	1.80	48.0

NiCd-Cells with fibrestructured electrodes							
T 106 X	19	47	122	250	2.7	0.50	3.8
T 110 X	33	72	122	250	4	0.73	6.6
T 114 X	45	92	122	250	5.4	1.00	9.0
T 118 X	58	115	122	250	6.7	1.34	11.6
T 206 X	25	47	122	309	3.1	0.63	5.0
T 210 X	43	72	122	309	4.9	1.04	8.6
T 214 X	60	92	122	309	6.1	1.30	12.0
T 218 X	77	115	122	309	7.5	1.60	15.4
T 202 M	38	47	122	309	2.5	0.64	7.6
T 203 M	57	47	122	309	2.8	0.45	11.4
T 204 M	76	72	122	309	3.9	1.08	15.2
T 205 M	95	72	122	309	4.4	0.92	19.0
T 206 M	114	92	122	309	5.4	1.14	22.8
T 207 M	133	92	122	309	5.7	1.00	26.6
T 208 M	152	115	122	309	7	1.50	30.4
T 209 M	171	115	122	309	7.3	1.35	34.2
T 306 M	186	92	194	309	8.6	1.90	37.2
T 307 M	217	92	194	309	8.9	1.70	43.4
T 308 M	248	115	194	309	10.9	2.15	49.6
T 309 M	280	115	194	309	11.5	1.80	56.0

According to DIN IEC 623 the nominal voltage of a NiCd-cell is 1.2 Volt!
Height above vent plug



Verwaltung und Vertrieb / Sales & Administration
HOPPECKE Batterie Systeme GmbH

P.O.Box 1140 • D-59914 Brilon • Hotline 02961/97 06-214 • Fax 02961/97 06-251
e-mail: HOPPECKE.AB@t-online.de • www.hoppecke.com